

Research Article

Properties of chicken manure pyrolysis bio-oil blended with diesel and its combustion characteristics in RCEM, Rapid Compression and Expansion Machine

Sunbong Lee *, Shaku Tei, Kunio Yoshikawa

Yoshikawa Lab, Department of Environmental Science and Technology, Tokyo Institute of Technology, Kanagawa, Japan

* **Correspondence:** E-mail: wte.sblee77@gmail.com; Tel: +81-90-6526-4541.

Abstract: Bio-oil (bio-oil) was produced from chicken manure in a pilot-scale pyrolysis facility. The raw bio-oil had a very high viscosity and sediments which made direct application to diesel engines difficult. The bio-oil was blended with diesel fuel with 25% and 75% volumetric ratio at the normal temperature, named as blend 25. A rapid compression and expansion machine was used for a combustion test under the experimental condition corresponding to the medium operation point of a light duty diesel engine using diesel fuel, and blend 25 for comparison. The injection related pressure signal and cylinder pressure signal were instantaneously picked up to analyze the combustion characteristics in addition to the measurement of NO_x and smoke emissions. Blend 25 resulted in reduction of the smoke emission by 80% and improvements of the apparent combustion efficiency while the NO_x emission increased by 40%. A discussion was done based on the analysis results of combustion.

Keywords: Chicken manure; Pyrolysis; Blend fuel; RCEM; Heat Release; Exhaust gas emission

1. Introduction

From the view point of effective usage of energy resources, much research concerning the application of bio-oil from biomass (bio-oil) have been carried out. Application and research results in many institutes to adapt bio-oil derived from woody biomass to compression ignition engines were reviewed [1]. Solantausta, et al. ran a diesel engine fueled by bio-oil from hardwood feedstock and reported that combustion duration of bio-oil was shorter than that of diesel fuel and found damage in engine systems such as cocked injection nozzle and combustion chamber deposits [2]. Chiaramonti,

et al. operated a single cylinder direct injection diesel engine by using emulsified pyrolysis pine oil with diesel and reported engine troubles in injector nozzle and fuel supply pump [3]. Eucalyptus/diesel blends were tested in a single cylinder direct injection diesel engine and the smoke and THC emissions were reduced according to increasing the ratio of blending up to 50% while NO_x increased due to longer ignition delay which enlarged the portion of premixed combustion [4]. Diesel spray was investigated for coconut oil/diesel blends and averaged liquid particle diameter in the spray describing the quality of air-fuel mixture formation, the smaller the better, increased by raising the blend ratio. Nevertheless, compared with diesel fuel, the smoke emission was reduced by 12% due to the presence of oxygen in coconut oil while NO_x decreased by 36% caused by shortened ignition delay [5]. Carlos et al. reported the physical and chemical characteristics of raw pyrolysis bio-oil produced from chicken manure and upgraded bio-oil compatible to diesel fuel [6].

On the other hand, there has been almost no study on the adaption of bio-oil obtained from chicken manure to compression ignition engines. The present paper reports on an application of diesel/bio-oil blend fuel to RCEM, Rapid Compression and Expansion Machine, which simulates a single cycle run of a diesel engine, and discussions on its combustion characteristics compared with diesel will be presented.

2. Materials and Methods

2.1. Bio-oil production

Bio-oil of chicken manure was produced using the pilot-scale gasification plant shown in Figure 1. The gasification reactor is an updraft gasifier. Air was supplied from the bottom of the reactor as a gasifying agent. The dried chicken manure (water content was less than 20%) was supplied continuously using the screw. When the feedstock was supplied into the reactor, the volatiles of the feedstock would be released as syngas, called producer gas. The producer gas was cleaned by the tar

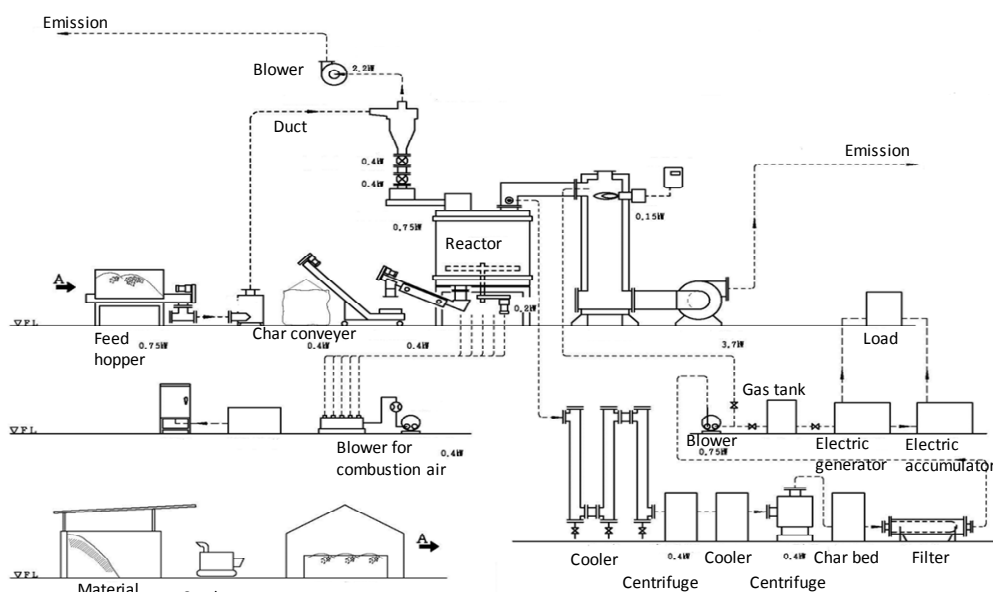

Figure 1. Process scheme of the pilot-scale gasification plant.

removal process, which consists of two water coolers, two centrifuges and a char bed. After the tar removal process, the producer gas was introduced into a spark ignition gas engine. From the bottom of the gasifier, char was discharged by an agitator and a screw conveyor. In the 1st cooler, water and heavy tar contents in the producer gas were removed and the bio-oil was mainly recovered in the 1st centrifuge. The mass balance of the bio-oil production is shown in Figure 2.

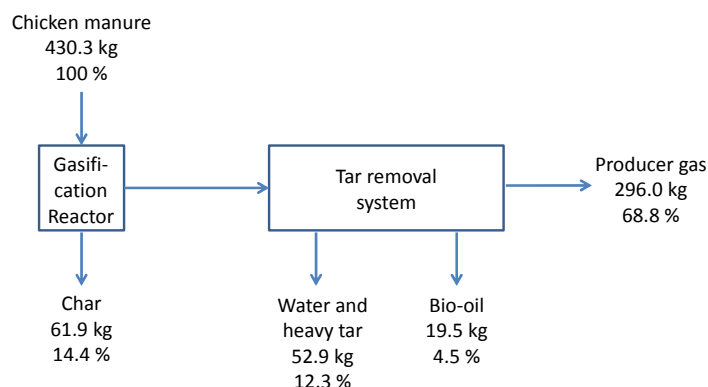

Figure 2. Mass balance of the bio-oil production from chicken manure.

2.2. Test fuels

In this facility, dried chicken manure is pyrolyzed in an updraft gasifier. The pyrolysis gas was first water cooled to condense water and heavy tar as much as possible. Then centrifugal equipment was utilized to collect medium to light tar, which was the bio-oil utilized in this study. The raw bio-oil had a higher kinematic viscosity than diesel fuel as shown in Table 1 and many residues which were mainly composed of viewable solid particles and highly dense liquid conglomerate. Those are some of the reasons to make its direct adaption to diesel engines difficult, due to unfavorable and unpredictable troubles in engine systems. Many researchers have attempted to upgrade and refine quality of bio-oil [7,8]. Those treatments can distinctively improve compatibility

Table 1. Properties of diesel, blend 25 and raw bio-oil.

Composition analysis			
%wt/wt	Diesel [JIS2]	Blend 25 [75%-25%]	Raw bio-oil [Chicken manure]
C	85.04	83.11	56.01
H	13.55	12.96	8.46
N	0	0.42	3.32
S	0	0	0
O	0	-	26.4
Physical property			
Density [kg/cm ³]	0.83	-	1.12
Kinematic viscosity [mm ² /s]	2.744	-	9.05
Water content [%wt/wt]	Trace	14.34	36.79
Low Heat value [MJ/kg]	45	41.7	24.95

with diesel fuel but need a large amount of effort and costs. In the present investigation, a least treatment process was made to adapt the raw pyrolysis bio-oil to diesel engines. The raw bio-oil was mixed with diesel fuel at the normal temperature with the volumetric ratios of 25% and 75%, respectively, and then filtered to remove the undesirable matter as mentioned above. A Whatman No. 41 filter was used for the filtration because the pore size 20–25 micro meter was compatible to that of the upgrade filter for commercial use in diesel engines. The processed bio-oil was named as blend 25 and its properties are shown in Table 1.

2.3. Experimental procedure

The overall experimental apparatus is illustrated in Figure 3. It consists of mainly three parts: a rapid compression and expansion machine for combustion test (RCEM), a common rail injection system and air delivery and exhaust gas emission measurement. RCEM [10] is not a real diesel engine, but can simulate the diesel combustion process for a single running cycle. The hydro-mechanical device drove a piston to compress conditioned artificial air very rapidly and stopped at its top position and then fuel was injected and combustion followed after a certain ignition delay. During combustion, the piston was kept stopped at the top position for the equal time to the compression process. Artificial air which consists of 21% oxygen and 79% nitrogen by volume was heated up to 493.14 K in the heating chamber and supplied to the cylinder controlling pressure by 0.23 MPa before the start of the compression process. After the combustion process, the whole burned gas was released outside of the cylinder and the smoke and NO_x concentrations were sequentially measured by the smoke meter and by the chemiluminescence meter, respectively [11], for comparing emission gasses. The fuel pressure at the high pressure line connected with the injector and the common rail and the in-cylinder pressure during compression and combustion were instantaneously picked up by using piezo-electric type pressure transducers during the single test cycle for analysis of combustion.

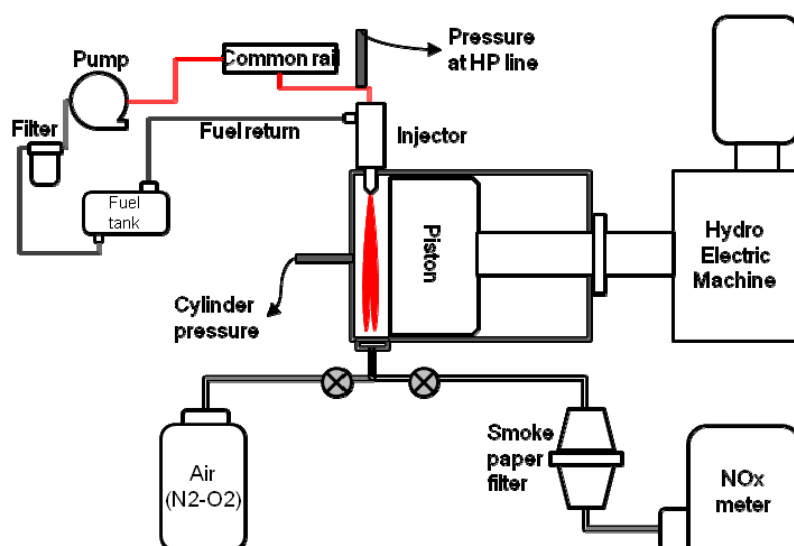

Figure 3. Experimental apparatus.

The surrounding condition when the piston finished its compression process was 5 MPa in pressure and 720 K in temperature, which is shown in Table 2. This condition was selected to

simulate the middle engine operating point represented by the engine speed and the load of an off-road light duty diesel engine. Air excess ratio was 2 in the case of diesel injection.

Table 2. Surrounding conditions at the top position of the piston.

Operating gas	Air 21%, N ₂ 79%
Gas temperature [K]	720
Pressure [MPa]	5
Density [kg/m ³]	24
Air excess ratio, λ [-]	2

Combustion tests were done for diesel 100% and blend 25, and the injection conditions were equal for two combustion tests as described in Table 3. The amount for a single diesel injection shot was 32.4 mg under the injection parameterization which was 128 MPa in the common rail fuel pressure and 2.6 ms in the electrical charge injection duration. There was no direct metering for injection quantity of blend 25 and based on the density information of diesel fuel and bio-oil, it could be estimated as 35.2 mg making the air excess ratio a little bit smaller than 2. It can be negligible because the air excess ratio 2 is high enough.

Table 3. Conditions of the fuel injection at single event.

Nozzle hole no. [-]	1
Nozzle diameter [mm]	0.24
Common rail pressure [MPa]	128
Injection duration [ms]	2.6
Injection quantity [mg]	
Diesel JIS2	32.4
Blend 25	35.2

3. Results and discussion

3.1. Combustion analysis

Figure 4 illustrates the experimental results for a single combustion cycle. When a single injection event occurred, actual start and end of injection could be defined by analyzing the pressure wave in a high pressure line. The injection started around 45.5 ms where high pressure dropped suddenly from its original fuel control pressure of 128 MPa and finished around 49.5 ms where high fuel pressure recovered its controlling pressure after several pressure fluctuations. There is no significant difference in the two high pressure waves even considering the difference of the amount of injection. It is thought to be because 2.8 mg deviation in the quantity was too small to affect the high pressure wave. The cylinder pressure which was picked during the compression and combustion event was processed to acquire the heat release rate, the mass burned fraction and the mean temperature. The ignition delay was defined by the time from the start of the fuel injection to the start of combustion where the first rapid increase of the heat release rate took place [12]. The ignition delay of blend 25 was slightly shorter than that of diesel as shown on the small figure inserted in

Figure 2. The pre-mixed combustion phase defined by the first mountain shape of the heat release rate followed the ignition delay, and the heat release rate of blend 25 was lower than those of diesel fuel due to the shortened ignition delay. However, during the mixing controlled combustion phase following the pre-mixed combustion phase, the heat release rate of blend 25 showed a higher peak than those of diesel fuel. It could lead combustion of blend 25 to finish in almost equal time to the case of diesel fuel as shown in the mass burned fraction graph in Figure 2 even though the injection quantity of blend 25 was 2.8 mg more than diesel fuel. It is thought that the combustion of blend 25 during the mixing controlled phase is more active than that of diesel fuel due to the presence of oxygen in blend 25 coming from bio-oil.

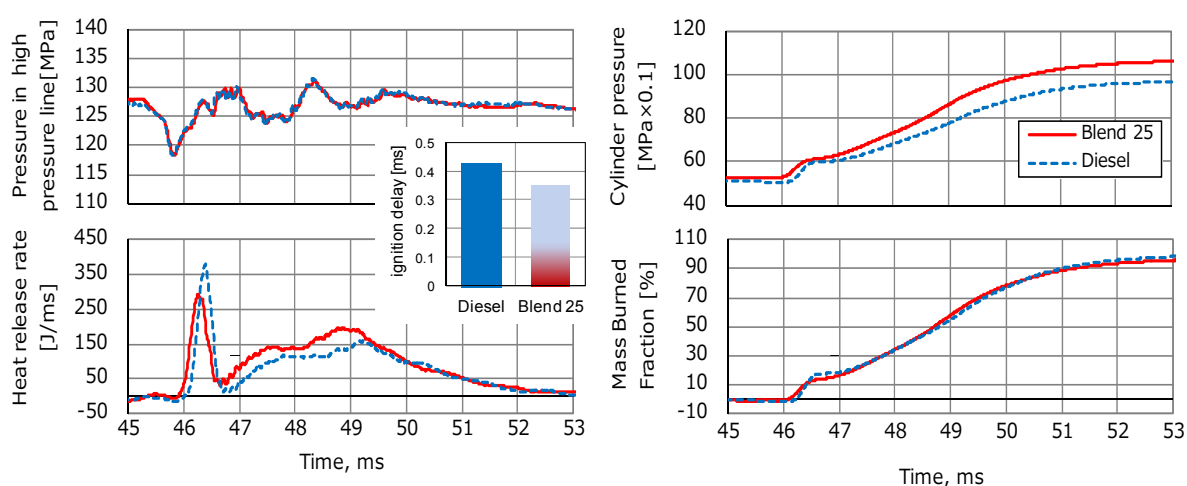

Figure 4. Experimental results for combustion analysis, rail pressure, cylinder pressure, heat release rate and mass burned fraction.

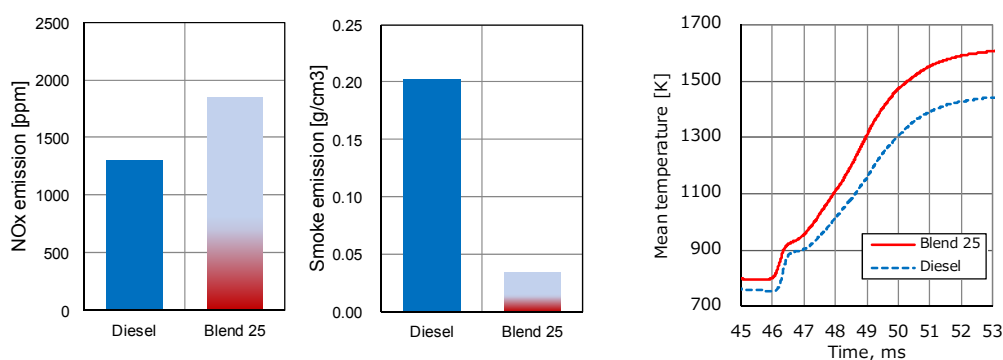

Figure 5. Exhaust gas NO_x and smoke emissions and the mean temperature.

3.2. Exhaust gas NO_x and smoke emissions

Figure 5 depicts the result of the exhaust gas NO_x and smoke emissions. For blend 25, NO_x increased up to about 40% and the smoke decreased by around 80%. Considering the discussion in the combustion analysis section above and the other research results on combustion and emissions of oxygen-containing bio fuels [5,13], this tendency makes sense. In the mixing controlled combustion phase, the flame temperature which is referred to as the mean temperature here shown in the far right

side in Figure 3 was higher in the case of blend 25. This may result in the increase of the NO_x emission, while the oxidation of soot was enhanced by the aid of oxygen contained in blend 25. There seems to be enough potential to improve the trade-off characteristics of NO_x and smoke emissions by optimizing parameters of the injection system [14].

3.3. Apparent combustion efficiency

For comparing the efficiency, the apparent combustion efficiency was introduced by dividing the actual heat release due to combustion by the theoretical potential heat in fuel. The theoretical heat of fuel was calculated by multiplying the low heat value and the fuel injection quantity listed in Table 1 and 3, respectively. For the actual heat release due to combustion, the heat release rate shown in Figure 2 was integrated in the range of combustion. Actually, the heat accumulation at the time of 90% mass burned fraction was used, because in many cases it is difficult and prone to error to define the end of combustion in the late combustion phase from the heat release rate.

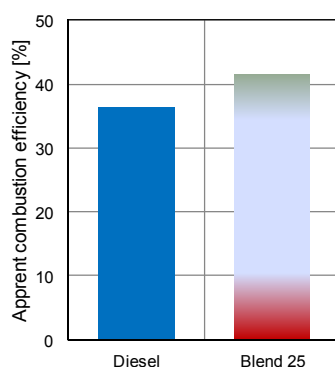

Figure 6. Comparison of the apparent combustion efficiency.

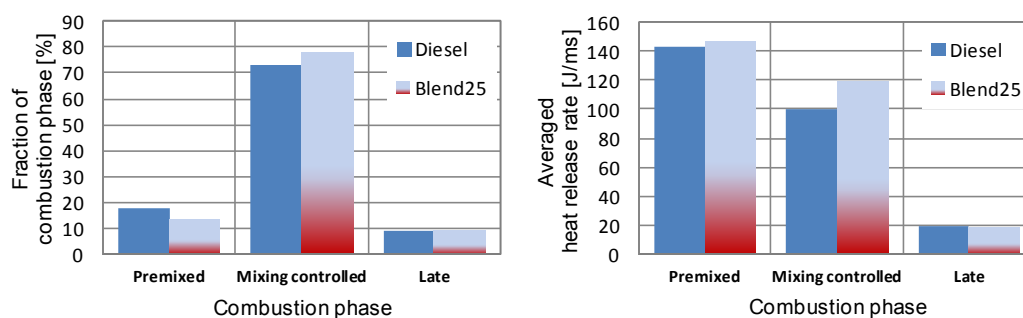

Figure 7. Left : Fraction of the combustion phase, Right : Phase averaged heat release.

Blend 25 showed about 25% higher apparent combustion efficiency than that of diesel fuel as illustrated in Figure 6. Considering possible errors in the process of calculation of the apparent combustion efficiency and its dependability, this efficiency improvement seems to be slightly over estimated but the tendency appears to be acceptable based on the result of combustion analysis. The mixing controlled combustion dominated around 72% for diesel fuel and even higher 77% for blend

25 in the whole combustion phase shown in the left of Figure 7. The heat release speed presented by the averaged heat release rate, which was calculated by dividing the accumulated heat by the combustion duration for each phase, shown in the right of Figure 5, was 20% faster for blend 25 than for diesel fuel, and this could contribute to terminate combustion in almost equal times for both fuels as mentioned above.

4. Conclusion

Raw bio-oil derived from chicken manure was blended with diesel fuel and filtered because of its low flow characteristic and unfavorable matter. A rapid compression and expansion machine, RCEM, simulating a single diesel combustion cycle was used for a combustion experiment with regard to diesel only and blend 25 made with the mixing ratio of 25% bio-oil and 75% diesel fuel in volume.

For the given experimental conditions, the ignition delay of blend 25 was slightly shorter than that of diesel fuel. The combustion period was almost dominated by the mixing controlled combustion phase for the two fuels. During the mixing controlled combustion phase, blend 25 showed a higher mean temperature and a faster heat release rate contributing to complete combustion in almost the equal time even with more injection amount than that of diesel. This resulted in less smoke emission by 80% and higher apparent combustion efficiency while NO_x emission increased by 40% comparing to diesel fuel.

Acknowledgement

The authors would sincerely like to thank for the cooperative support for this study provided by Professor Kosaka, Mr. Takahashi, Mr. Uchida and Mr. Koike in the Kosaka Internal Combustion Engine Laboratory at Tokyo Institute of Technology.

Conflict of Interest

All authors declare no conflict of interest in this paper.

References

1. Charles JM (2013) The Feasibility of Using Raw Liquids from Fast Pyrolysis of Woody Biomass as Fuels for Compression-Ignition Engines: A Literature Review. *SAE Int J Fuels Lubr* 6: 251-262.
2. Solantausta Y, Nylund NO, Westerholm M, et al. (1993) Wood-Pyrolysis Oil as Fuel in a Direct-Power Plant. *Bioresour Technol* 46:177-188.
3. Chaiaramonti D, Bonini A, Fratini E, et al. (2003) Development of Emulsions from Biomass Pyrolysis Liquid and Diesel and Their Use in Engines—Part2: Test in Diesel Engines. *Biomass Bio energ* 25:101-111.
4. Devan PK, Mahalakshii NV (2008) An Experimental Investigation on Performance and Emission Characteristics of Eucalyptus Oil-Diesel Blends in a D.I. Diesel Engine. *SAE Paper* 2008-01-0757.

5. Herchel CM, Seiichi S, Yutaka M (2001) Operation and Combustion Characteristics of a DI Diesel Engine Fueled with Biomass Oil-Diesel Fuel Blends. *SAE Paper* 2001-28-0030.
6. Carlos MM, Morris S (2011) Production of a refined biooil derived by fast pyrolysis of chicken manure with chemical and physical characteristics close to those of fossil fuels. *J Env Sci Hea Part B* 46: 630-637.
7. Augustinova J, Cvengrosova Z, Mikulec J, et al. (2013) Upgrading of biooil from fast pyrolysis. 46th International Conference on Petroleum Processing, June 7, Bratislava, Slovak Republic.
8. Xu YF, Hu XG, Li WD, et al. (2011) Preparation and Characterization of Bio-oil from Biomass, In: Dr. Shahid Shaukat Editor, *Progress in Biomass and Bioenergy Production*, In Tech. Available from:
<http://www.intechopen.com/books/progress-in-biomass-and-bioenergy-production/preparation-and-characterization-of-bio-oil-from-biomass>
9. Schnizer MI, Monreal CM, Facey GA, et al. (2007) The Conversion of Chicken Manure to Biooil by Fast Pyrolysis I. Analysis of Biooils by FTIR and NMR Spectroscopy. *J Env Sci Hea Part B* 42: 71-77.
10. Shigeharu K, Takeyuki K (1995) Development of a Rapid Compression-Expansion Machine Simulating Diesel Combustion. *SAE Paper* 952514.
11. Hidenori K, Kentaro N, Tetsuya A (2007) A Study of Effect of Heterogeneity of Oxygen Concentration of Mixture in a Combustion Chamber on Combustion and Emissions of Diesel Engine. *SAE Tech Paper* 2007-01-1845.
12. Heywood JB (1988) *Internal Combustion Engine Fundamental*. McGraw-Hill, NY: 505-506.
13. Jurgen K, Gerhard K, Axel M, et al. (2008) Comparison of exhaust emissions and their mutagenicity from the combustion of biodiesel, vegetable oil, gas-to-liquid and petrodiesel fuels. *Fuel* 88: 1064-1069.
14. Andreas J, Martin M, Stefan P, et al. (2009) Tailor-Made Fuels: The Potential of Oxygen Content in Fuels for Advanced Diesel Combustion Systems. *SAE Tech Paper* 2009-01-2765.

© 2014, Sunbong Lee, et al., licensee AIMS Press. This is an open access article distributed under the terms of the Creative Commons Attribution License (<http://creativecommons.org/licenses/by/4.0>)